

HYUNDAI
POWER PRODUCTS

STUMP GRINDER

HYSG150-2

User Manual

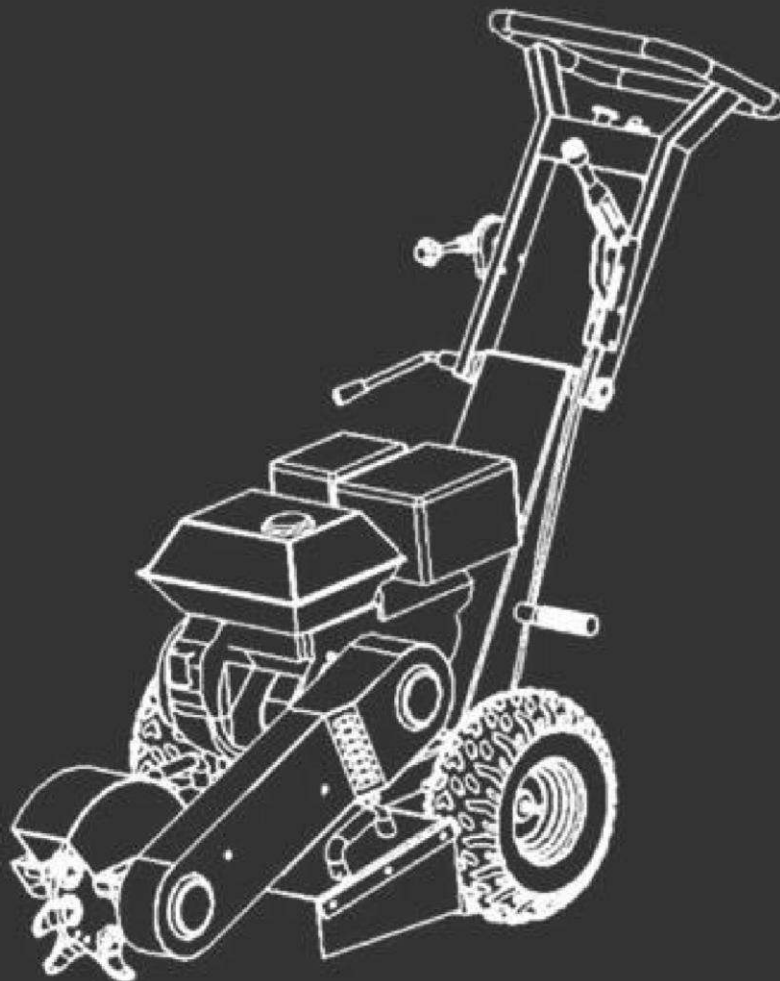

INDEX

	CONTENTS	PAGE NO.S
1	SAFETY	3 - 8
2	ASSEMBLY	9 - 10
3	FUEL & OIL	11 - 12
4	STARTING PROCEDURE	13
5	STOPPING PROCEDURE	13
6	OPERATION	14 - 18
7	MAINTENANCE	18 - 22
8	STORAGE & WINTERIZATION	23
9	TRANSPORTATION	23
10	TROUBLE SHOOTING	24
11	SPECIFICATION	26
12	DECLARATION OF CONFORMITY	27
13	RECYCLING & PRODUCT DISPOSAL	28
14	CONTACT DETAILS / WARRANTY	29

1. SAFETY

1.1 General Safety Notes.

- 1.2 The operator of the machine is responsible for, and has a duty of care in making sure that the machine is operated safely and in accordance with the instructions in this user manual. Keep the manual safe and pass it on if the machine is loaned or sold to another user.
- 1.3 Please note the following safety points.
- 1.4 The machine should never be left in a condition which would allow an untrained or unauthorised person/s to operate this machine.
- 1.5 All due care and diligence should be taken by the operator for the safety of and with regard to those around whilst using the machine.
- 1.6 Some or all of the following - warning signs, symbols and/or PPE pictograms may appear throughout this manual. You **MUST** adhere to their warnings. Failure to do so may result in personal injury to yourself or those around you.



DANGER

Indicates a hazard, which, if not avoided, could result in serious injury or death.



WARNING

Indicates a hazard, which, if not avoided, could result in serious injury.



CAUTION

Indicates a hazard which, if not avoided, might result in minor or moderate injury.



NOTE

Indicates a situation that could easily result in equipment damage.

READ and keep the manual safe and pass it on if the machine is loaned or sold to another user.

You **MUST** fully understand all instructions to ensure you use and operate the machine safely.

Appropriate Personal Protective Equipment (PPE), **MUST** be worn at all times when operating or repairing the machine.



HAND
PROTECTION
MUST BE WORN



EYE
PROTECTION
MUST BE WORN



PROTECTIVE
CLOTHING
MUST BE WORN



HEARING
PROTECTION
MUST BE WORN



FOOT
PROTECTION
MUST BE WORN



HEAD
PROTECTION
MUST BE WORN



RESPIRATOR
MUST BE WORN



FACE SHIELD
MUST BE WORN

1.10 Carbon Monoxide (where applicable).

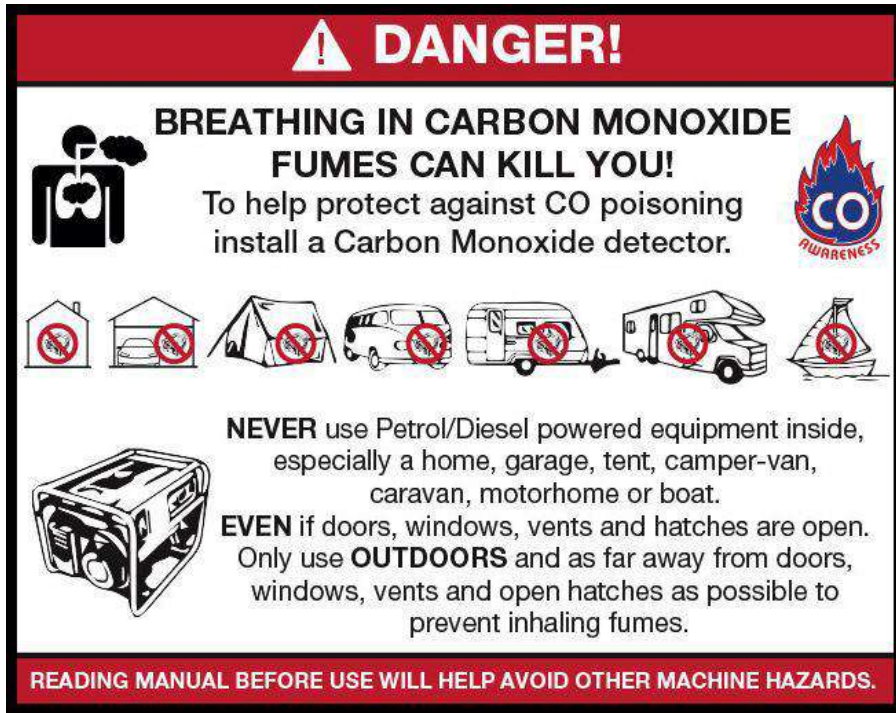

- 1.11 Carbon monoxide is a colourless and odourless gas. Inhaling this gas can cause death as well as serious long term health problems such as brain damage.
- 1.12 The symptoms of carbon monoxide poisoning can include but are not limited to the following;
Headaches, dizziness, nausea, breathlessness, collapsing or loss of consciousness.
- 1.13 Carbon monoxide poisoning symptoms are similar to flue, food poisoning, viral infections and simply tiredness. It is quite common for people to mistake this very dangerous poisoning for something else.
- 1.14 To avoid carbon monoxide poisoning **DO NOT** use Petrol/Diesel powered equipment inside any of the following; Home, garage, tent, camper van, mobile home, caravan or boat. This is not exhaustive and if you are in any doubt contact your dealer.
- 1.15 If you think you have or someone around you has been affected by carbon monoxide poisoning;
- 1.16 Get them fresh air immediately, by leaving the affected area or by opening doors and windows. If safe and practical to do so make sure that the machine is turned off. **DO NOT** enter a room you suspect of having carbon monoxide present – instead call the emergency services.
- 1.17 Contact a Doctor immediately or go to Hospital – let them know that you suspect carbon monoxide poisoning.
- 1.18 **DO NOT** use in an enclosed area or moving vehicle.

1.20 **General Fuel Safety (where applicable).**



CAUTION

ALL FUELS ARE FLAMABLE

1.21 Fire Hazard – keep fuel away from all sources of ignition for example heaters. Lamps, sparks from grinding or welding.



1.22 **DO NOT** carry out hot work on tanks that have contained fuel.

1.23 **ALWAYS** keep the work area tidy.

1.24 **ALWAYS** clean up spills promptly using absorbent granules and a lidded bin.

1.25 **ALWAYS** dispose of waste fuels correctly.

1.30 **Fueling/De-fueling (where applicable).**



CAUTION

ALL FUELS ARE FLAMABLE

1.31 **ALWAYS** fuel and defuel in a well ventilated area outside of buildings.

1.32 **ALWAYS** wear correct, suitable and fit for purpose Personal Protective Equipment (PPE), suggested items are but not limited to safety gloves, overalls.



1.33 When fueling/de-fueling **ALWAYS** avoid inhaling fumes.

1.34 When de-fueling **ALWAYS** use a proper fuel retriever.



1.35 **ALWAYS** carry fuel in the correct and clearly marked container.

1.40 **Electrical Safety (where applicable).**

1.41 Electricity can kill – **NEVER** work on **LIVE/ENERGISED** equipment.

1.42 Prior to carrying out any maintenance work you **MUST** identify electrical isolation methods and isolate all electrical supplies.

1.43 Prior to use and with all electrical supplies isolated, you **MUST** check all electrical cables, plugs and connectors for the following;

1.44 Are intact and have no signs of damage, to include but not limited to bare wires, chaffing, cuts and loose wiring.

1.45 If there are any signs of damage, the damaged item **MUST** be taken out of service until the damage has been repaired by an electrically competent person.

1.46 All trailing cables should be routed so as not to cause any kind of trip hazard.

1.47  **NEVER** work on or near electricity with wet hands, wet clothing and wet gloves.



1.50 Batteries (where present).

1.51 Batteries present a risk if they become damaged by the possible leaking of electrolyte. This electrolyte is an acid and can cause serious burn injuries. Care should be taken when working on or near them. **NOTE** the electrolyte may be in a liquid or gel form.

1.52 Should you come in to contact with electrolyte you should;

1.53 Remove all clothing contaminated with electrolyte. If you cannot remove then saturate them in water.

1.54 Get medical assistance as soon as possible. You must advise the medical staff of the type of acid.

1.55 Lead/acid battery = dilute sulphuric acid.

1.56 Nickel/cadmium = potassium hydroxide alkali electrolyte.

1.57 Use fresh running water to wash off excess electrolyte, continue this until medical assistance arrives. Make sure that you do not wash the electrolyte to another part of your body or face.

1.58 If electrolyte comes in to contact with Eyes the electrolyte needs to be immediately washed away with large amounts of water. Make sure that you do not wash the electrolyte to another part of your face or body.

1.59 Gasses from charging batteries are highly flammable and great care should be taken to charge in well ventilated areas.

1.59.1  There is an explosion risk if the battery terminals are short circuited, when connecting/disconnecting **ALWAYS** exercise great care so that the terminals or battery leads are **NOT** allowed to touch and cause a spark. **ALWAYS** use suitable insulated tools.



1.60 Vibrations (where applicable).

1.61 Prolonged use of hand held (operated) machines will cause the user to feel the effects of/from vibrations. These vibrations can lead to white finger (Raynaud's phenomenon) or carpal tunnel syndrome. This condition reduces the ability of the hand to feel and regulate temperature, causing numbness and heat sensations and may cause never damage and circulatory tissue death.

1.62 Not all factors that lead to white finger disease are known, but cold weather, smoking and other diseases that affect blood vessels and blood circulation as well as large and long-lasting impact of shocks are considered factors in the formation of white finger. Note the following to reduce the risk of white finger and carpal tunnel syndrome;

1.63 Wear gloves and keep your hands warm.

1.64 Take regular breaks.

1.65 All of the above precautions may help reduce the risk of white finger disease but not rule out the carpal tunnel syndrome. Long-term and regular users are therefore

recommended to observe the condition of your hands and fingers. Seek medical attention immediately if any of the above symptoms should occur.

1.70 Noise (where applicable).

- 1.71 The operating noise of the machine can damage your hearing. Wear hearing protection such as earplugs or ear defenders to protect your hearing. Long-term and regular users are advised to have hearing checked regularly. Be especially vigilant and cautious when hearing ear protection because your ability to hear alarm warnings will be reduced.
- 1.72 Noise emissions for this equipment is unavoidable. Carry out noisy work at approved times and for certain periods. Limit the working time to a minimum. For your personal protection and protection of people working nearby it is also advisable for them to wear hearing protection.
- 1.73  See Certificate of Conformity section for Outdoor Noise declaration of conformity.

MACHINE SPECIFIC SAFETY

1.80 General Machine Safety.

- 1.81 Read the owner's manual carefully to understand how to operate this machine properly.
- 1.82 You should **NEVER** use the machine when;
- 1.83 Wearing loose clothing, barefoot or sandals.
- 1.84 Under the influence of drink or drugs or as a result of having taken medication for cold or flu, or any other times when a possibility exists that your judgement might be impaired or that you might not be able to operate the machine properly and in a safe manner.
- 1.85 Suffering from exhaustion or lack of sleep.
- 1.86 When the ground is slippery or when other conditions exist which might make it not possible to maintain a steady posture.
- 1.87 At night, at times of heavy fog, or at any other times when your field of vision might be limited and it would be difficult to gain a clear view of the area.
- 1.88 During rain storms, lightning storms, at times of strong or gale force winds, or at any other times when the weather conditions might make it unsafe to use this product.
- 1.89 **NEVER** run the engine indoors. The exhaust gasses contain harmful carbon monoxide.
- 1.90 When using this machine for the first time and before actual work, you **MUST** learn how to handle the machine from an experienced or skilled person.
- 1.91 Limit the amount of time using the machine continuously to somewhere around 10 minutes per session and take 10 to 20 minutes of rest between sessions. Also try to keep the total amount of work in a single day limited to 2 hours or less.

- 1.92 **NEVER** allow children or anyone unable to fully understand the directions given in this manual to operate this product.
- 1.93 Make sure you keep this manual handy so you may refer to it whenever questions arise and ensure you pass this manual on if the machine is loaned or sold.
- 1.94 Correct Personal Protective Equipment (PPE) **MUST** be worn at all times when operating or repairing this machine. This should include but is not limited to;



HAND
PROTECTION
MUST BE WORN



EYE
PROTECTION
MUST BE WORN



PROTECTIVE
CLOTHING
MUST BE WORN



HEARING
PROTECTION
MUST BE WORN



FOOT
PROTECTION
MUST BE WORN



HEAD
PROTECTION
MUST BE WORN



RESPIRATOR
MUST BE WORN



FACE SHIELD
MUST BE WORN

2. ASSEMBLY

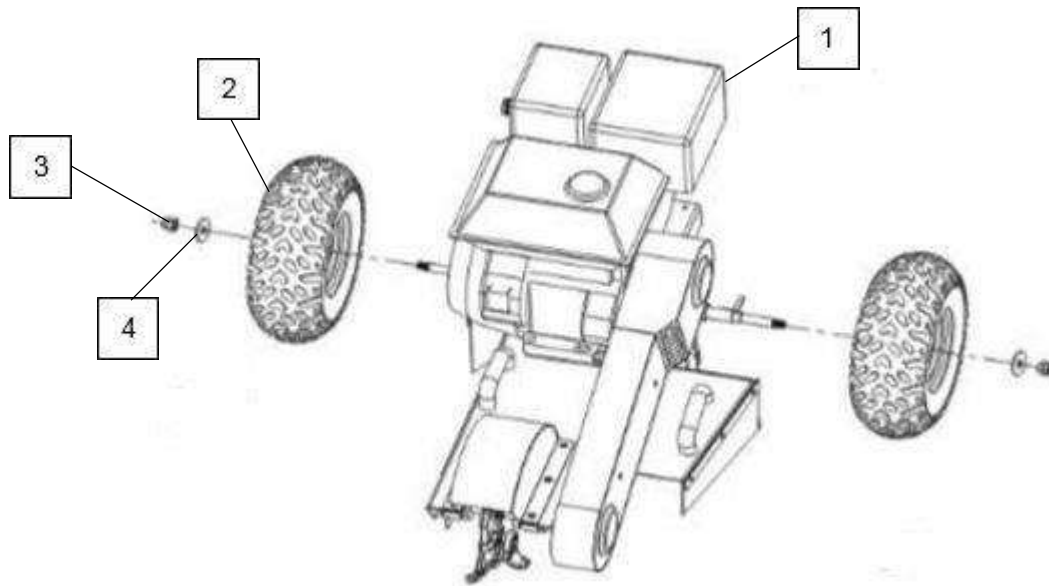

1	2	3	4
Engine	Wheel	Nut	Washer

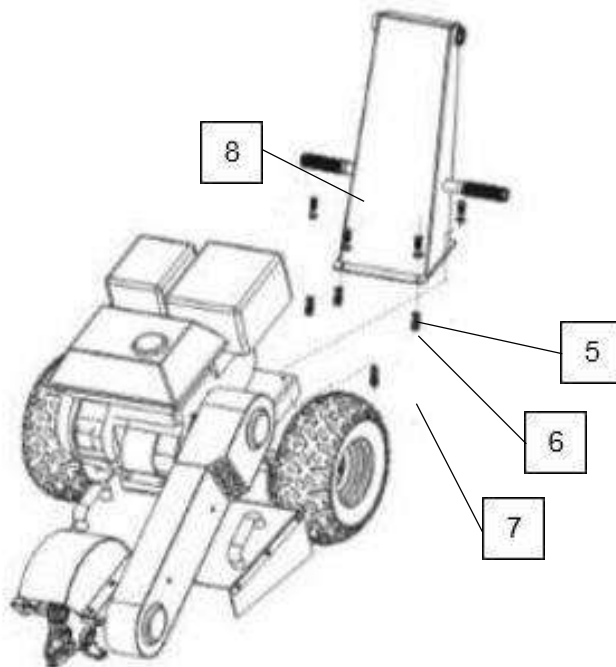

5	6	7	8
Bolt	Washer	Nut	Handle Support

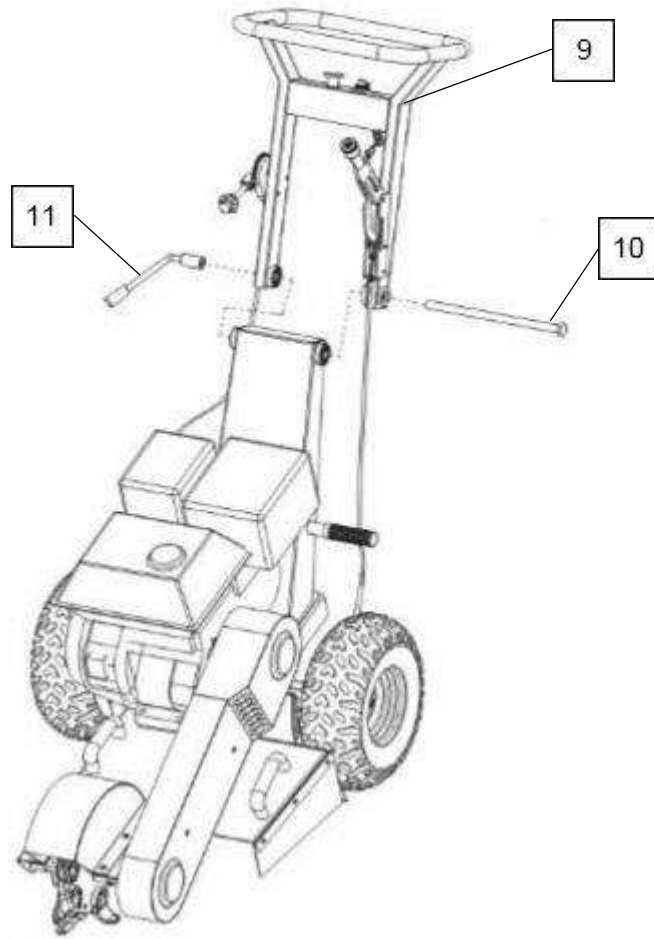

9	10	11
Upper Handle	Handle Bar Bolt	Handlebar Adjustment Lever

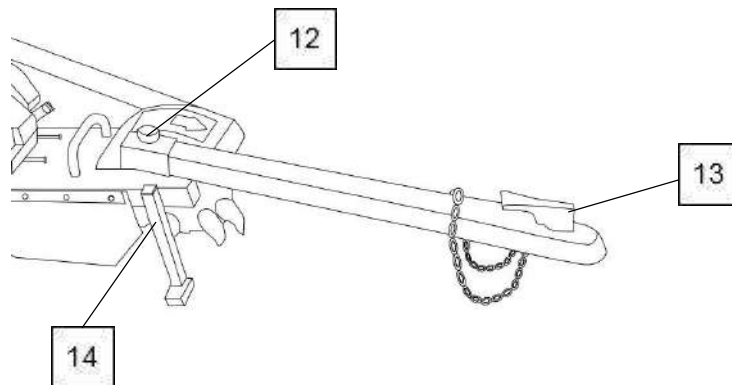

12	13	14
Tow Bar Lock Bolt	Tow Bar	Front Support Leg

3. FUEL & OIL



CAUTION

This machine is shipped **WITHOUT** Oil and Fuel and will require filling **BEFORE** use. Failure to do so will result in engine damage that will not be covered by the warranty.

Recommended Oil: SAE30 or 15W40 Engine Oil

Oil Capacity: 1200ml

Recommended Fuel: Straight Unleaded Petrol

Fuel Tank Capacity: 6Litres



CAUTION

FOR OUTDOOR USE ONLY.

This machine produces carbon monoxide – a poisonous, colourless and odourless gas that can cause death or serious injury.

Petrol is highly flammable, always handle with extreme care and in a well-ventilated area.

ALWAYS remove the spark plug HT lead from the spark plug when fuelling or de-fuelling the machine, checking or changing parts.

OIL

- 2.0 Place the stump grinder on a flat level surface.
- 2.1 Clean around the oil filler and remove the oil filler cap/dipstick. Wipe the dipstick clean.
- 2.2 Slowly fill the engine with oil through the oil filler until it reaches the upper thread. **DO NOT OVERFILL.**

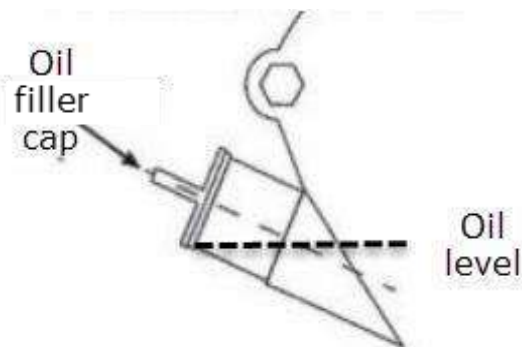

- 2.3 Stop occasionally to check the level.
- 2.4 Refit the oil filler cap/dipstick.
- 2.5 You **MUST** check the oil level before starting every session.



CAUTION

ALL FUELS ARE FLAMMABLE

ALWAYS fuel and defuel in a well-ventilated area outside of buildings.

ALWAYS wear correct, suitable and fit for purpose Personal Protective Equipment (PPE), suggested items are but not limited to safety gloves, overalls and eye protection.



CAUTION

DO NOT overfill the fuel tank, you **MUST** allow space for fuel expansion.

If the fuel tank is overfilled, fuel can overflow onto a hot engine and cause fire and/or explosion.

If fuel does spill, wait until it evaporates before starting the engine.

Check fuel lines, tank, cap and fittings frequently for cracks or leaks. Replace as required.

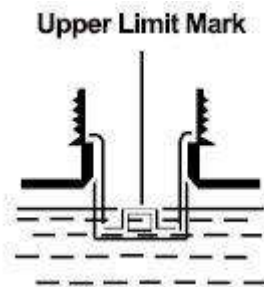

- 2.6 Place the stump grinder on a flat level surface.
- 2.7 Remove the fuel filler cap.
- 2.8 Slowly fill with fresh unleaded petrol to within 25mm of the top of the fuel tank.
- 2.9 Refit the fuel fill cap and tighten securely.

4. STARTING PROCEDURE

- 3.0 Lock the travel wheel by pulling the brake lever fully back.
- 3.1 Turn the fuel tap **ON**.
- 3.2 Turn the engine ON/OFF switch to **ON**.
- 3.3 Make sure the throttle is in the slow speed position.
- 3.4 If the engine is cold, move the choke to the closed/start position.
- 3.5 Raise the cutter wheel 4 to 5 inches off the ground by pushing downwards on the handlebar and hold in that position.
- 3.6 Pull the recoil start handle unit you feel resistance the pull swiftly.
DO NOT allow the starter handle to snap back, return it by hand to prevent damage to the starter.
This may cause the cutting wheel to rotate, keep everyone away.
- 3.7 When the engine starts, move the choke lever to the open/run position.
- 3.8 Allow the engine to run at a slow idle speed under no load for a few minutes to allow the engine to warm up before operation.

5. STOPPING PROCEDURE

- 4.0 In consideration for your own safety and that of others, you should always use the following shutdown procedure before leaving the machine for any reason.
Never deviate from this procedure unless so instructed in this manual or in an emergency.
- 4.1 Move the engine throttle lever to the slow position and allow the engine to idle under no load for a few minutes.
- 4.2 Press the engine emergency stop button and allow the engine to come to a complete stop.
- 4.3 Turn the engine ignition switch to the **OFF** position.
- 4.4 Turn the fuel tap to the **OFF** position.
- 4.5 Engage the park brake.

6. OPERATION

- 5.0 **DO NOT** use the machine on slopes greater than 10°
- 5.1 **DO NOT** use the machine if you are tired, consumed alcohol or if you are taking any drugs or medication that can affect your vision, judgement or coordination.
- 5.2 **NEVER** use the machine indoors or in spaces lacking proper ventilation.
- 5.3 Make sure you have a proper foothold when using the machine, particularly when walking backwards (which you should avoid).
- 5.4 Walk don't run.
NEVER work on wet grass, poor traction may cause you to slip and fall.
- 5.5 Keep your hands and feet away from moving parts and working tools.
DO NOT use your hands, feet or other parts of your body to gain greater bearing pressure against the stump.
- 5.6 Naked flames or sparks in the vicinity are strictly forbidden.
Petrol is extremely flammable and carelessness in handling can result in personal injury or fire.
- 5.7 **NEVER** use the machine with a defective exhaust or muffler.
- 5.8 In very warm and dry climates, stump grinder operation will pose a greater risk of starting fires.
- 5.9 Stop and inspect the equipment if you run over or into anything.
If any damage has occurred you **MUST** make all the necessary repairs before starting work again.
- 5.10 Whatever happens, you should always park the machine on even ground, disengage the drive, activate the parking brake, turn off the engine and wait until all moving parts have stopped before leaving the machine.
- 5.11 Beware of thrown objects, rotating cutters, **DO NOT** smoke in the vicinity of the machine.



Thrown objects



Rotating cutters



NO Smoking

- 5.12 Always use the approved protective clothing and approved protective equipment when using the machine.
Protective clothing and protective equipment cannot eliminate the risk of an accident but wearing proper clothing and the correct equipment will reduce the degree of injury should an accident occur.

Ask your dealer about approved protective clothing and approved protective equipment recommended.

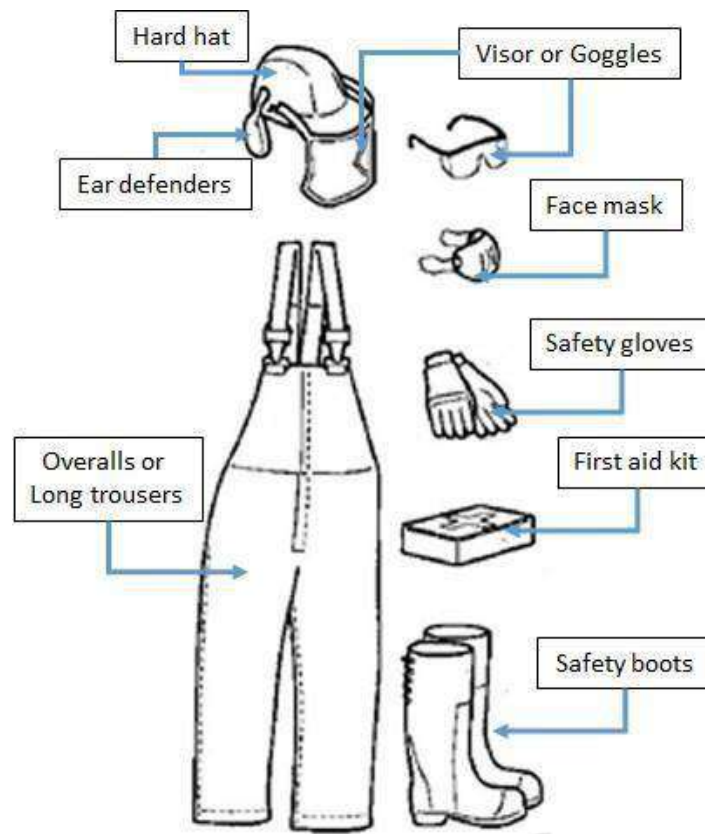

REMOVING STUMPS

- 5.13 Remove all loose pieces of wood, stones, wire and other debris from the area before beginning stump removal.
- 5.14 Wind direction should be considered as this influences the direction in which dust and wood chips are directed.
- 5.15 Dig around the earth and remove any stones near the stump that may interfere with your work.
Check that the ground is free of foreign objects such as, cables, barbed wire etc.



- 5.16 Cut or trim the stump as low to the ground as required using a power saw.
- 5.17 Never operate the stump grinder after dark. There will not be adequate lighting for the operator to use the machine safely.
- 5.18 Allow a cold engine time to warm up before use.
- 5.19 For best results, only use the portion of the cutting wheel within the 80° area shown below.

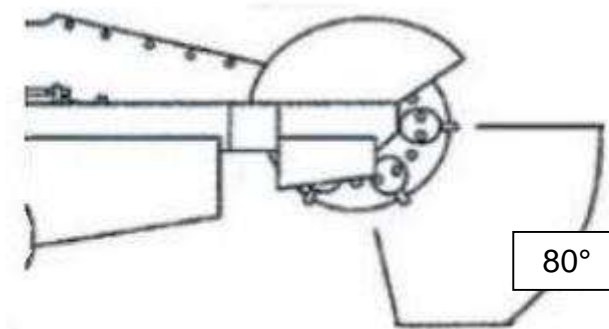

- 5.20 Never leave the controls when the cutting wheel is rotating and stop the engine when the machine is left unattended.
- 5.21 Use smooth comfortable side to side movements while operating, pivoting the arc on the locked left wheel.
- 5.22 When it is desired to cut smaller roots, it may be more effective to do so before rather than after cutting the main stump.
- 5.23 Should the chip build-up become excessive when cutting, stop the engine, wait for the cutting wheel to stop rotating, retract the machine from the stump and rake away the chips.
- 5.24 In order to prevent the wheels becoming stuck in the hole. Move the grinder to the other side of the stump to continue removal or by filling the hole with chips before continuing.

PREPARE THE GRINDER AT THE STUMP

- 5.25 Place the stump grinder into position with the cutting wheel near the top edge of the stump.



REMOVING ROOTS

- 5.26 Make sure the throttle is set to high speed, the cutter wheel will accelerate to cutting speed.
- 5.27 Swing the cutting wheel to one side, then lower it into the nearest roots that are buried at the foot of the stump.
- 5.28 Swing the cutting wheel before each sweep until the roots are sufficiently removed.

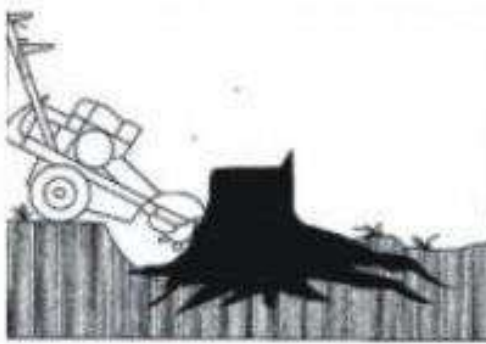

- 5.29 Raise the cutting wheel until the centre of the cutting wheel is just above the top of the stump.
- 5.30 Allow the cutter wheel to stop, release the brake and reposition the machine.
- 5.31 Lock the brake again.

CUTTING THE FULL STUMP

- 5.32 Make sure the throttle is set to high speed. The cutter wheel will accelerate to cutting speed.
- 5.33 Direct the cutter wheel against the stump, beginning with the nearest top corner of the stump and steadily sweep it across the stump left to right, cutting away $\frac{1}{2}$ " of wood with each sweep.
- 5.34 Raise and lower the cutter wheel between sweeps by lowering and raising the control handle.

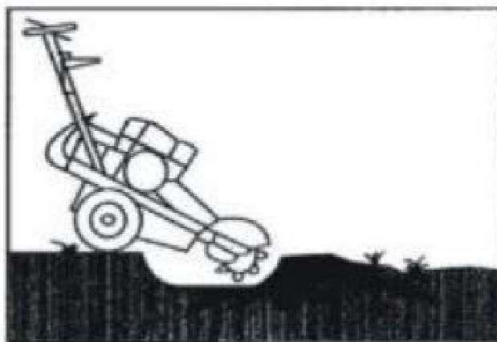

- 5.35 Roll the machine forward and back by pushing and pulling on the control handle. To do this, release the park brake. Relock it when the machine has been repositioned and continue cutting.

CONTINUE WITH FINAL ROOT REMOVAL

5.36 Cut the remaining roots as described until satisfactorily removed.

7. MAINTENANCE



WARNING

ALWAYS stop the engine allow to cool and unplug the spark plug HT lead cap before doing any repairs or maintenance.

Check and maintain the fuel level regularly and check engine oil level daily.

At regular intervals, check the tightness of all nuts, bolts and screws.

If the blade hits and obstacle, check for damage and if the machine vibrates badly, stop the machine and take it to a service dealer.



CAUTION

ALWAYS fuel and defuel in a well-ventilated are with the engine off and cool.

Whilst carrying out any maintenance you must wear the appropriate Personal Protective Equipment (PPE).



CAUTION

NEVER use a pressure washer or hose pipe to clean your stump grinder.

Water can penetrate areas of the machine and cause damage to spindles, pulleys, bearings or the engine.

The use of a pressure washer or hose pipe will result in a shortened life span and reduce serviceability.

Shut down the engine, wait for all moving parts to come to a complete stop, remove the spark plug HT lead cap and wait for 5 minutes before carrying out any maintenance.



NOTE

Only use manufacturer recommended parts when servicing or repairing this machine.

The use of non-recommended parts may shorted the machines lifespan and void the manufacturer's warranty.

		Each use	1st Month or 20 hours	Every 50 hours	Every 6 months or 100 hours	Every year or 300 hours
Engine oil	Oil Check	*				
	Replace		*		*	
Air Filter	Check	*				
	Clean			*	*	
Air filter Carburetor Float bowl Spark plug	Replace					*
	Clean				*	
	Clean / Adjust				*	
Carburettor Float bowl	Replace					*
Spark arrester	Clean				*	
Idle speed	Check / adjust					*#
Valve clearance	Check / adjust					*#
Fuel filter	Clean					*
Fuel tank	Clean					*
Fuel lines	Check	Check every 2 years – replace as required.				
Cylinder head	Clean	Every 500 hours #				
#- Unless you are mechanically proficient and have the correct tools we recommend that these service items are carried out by an authorised service dealer.						

- 6.1 Make sure all nuts, bolts and screws are tight.
- 6.2 Never store the equipment with petrol in the tank inside a building where fumes can reach an open flame or spark. Allow the engine to cool before moving the grinder.
- 6.3 To reduce fire hazards, keep the engine and petrol storage area free of grass, dirt and excessive grease.
- 6.4 Replace worn or damaged parts for safety. If the fuel tank has to be drained, this should be done outdoors.
- 6.5 Check the oil level daily and add engine oil if required. Change engine oil every 100 hours of use or every year, whichever comes first.
- 6.6 Frequently check the grinder and ensure to ensure all wood, bark and dirt deposits are removed from beneath the deck.
- 6.7 Grease the main cutting blade shaft bearings every 20 hours of use. There is a grease nipple on each bearing.



- 6.8 Check the tightness of all bolts and screws at regular intervals.
- 6.9 If the grinder hits an obstacle violently, stop the grinder and take it to a service dealer for inspection.

AIR FILTER

- 6.10 Never let the engine run without an air filter being installed. A dirty air filter element affects the engine performance, increases fuel consumption and makes it difficult to start.
If you notice a loss of engine power check the air filter.
You MUST make sure the housing is free of dust and debris DO NOT allow any dust or debris to enter the carburettor.
- 6.11 Remove the air filter cover by unscrewing the air filter cover wing nut and removing the cover.
- 6.12 Once the cover has been removed, undo the air filter element wing nut and remove the foam and paper elements.
- 6.13 If damaged or worn, replace immediately.
- 6.14 Wash the foam filter in a mild detergent solution and allow to dry.
- 6.15 Once dry, soak the foam in fresh engine oil and remove the excess.
- 6.16 Tap the paper element to remove dirt and debris and use a low pressure airline to blow from the inside of the element outwards to remove the remaining dust.
- 6.17 Reassemble and reinstall the air filter.



SPARK PLUG

- 6.18 The spark plug **MUST** be fully tightened otherwise the engine will overheat causing damage.
ALWAYS complete the following steps after the engine has been turned off and allowed to cool down.
- 6.19 To make sure the engine runs correctly a spark plug gap of 0.6 – 0.7mm must be maintained and the spark plug free of carbon deposits.
- 6.20 To remove the spark plug, remove the spark plug HT lead cap and undo the spark plug.
- 6.21 Inspect the spark plug and if worn or damaged, replace immediately.
- 6.22 Clean any carbon deposits with a soft wire brush and using a feeler gauge, gently tap the electrode until the correct gap is achieved.
- 6.23 Check the spark plug washer for damage and replace if required.
- 6.24 Replace the spark plug by hand to avoid cross threading then tighten to a torque of 12 to 15Nm.



ENGINE OIL



CAUTION

Risk of Burn from hot engine oil.

ALWAYS allow engine oil to cool before changing.

- 6.25 Drain the engine oil when the engine is warm, not hot. Warm oil drains more effectively.
- 6.26 Place a suitable container underneath the oil drain plug.
- 6.27 Remove the oil filler cap/dipstick.
- 6.28 Undo and remove the oil drain plug and allow the oil to drain into the container. You may need to tilt the machine to drain all the oil, you will require assistance for this.
- 6.29 Inspect the oil drain plug and washer and if damaged, replace.
- 6.30 Reinstall the oil drain plug.
- 6.31 Place the machine on flat level ground and slowly refill with 1200ml of SAE30 or 15W40 engine oil.
- 6.32 Stop occasionally to check the oil level and **DO NOT OVERFILL**.
- 6.33 Refit the oil filler/dipstick.
- 6.34 Dispose of the waste engine oil in a safe and correct manner. **DO NOT** throw waste oil down drains or on to the ground.
- 6.35 Clean up any spilt oil.

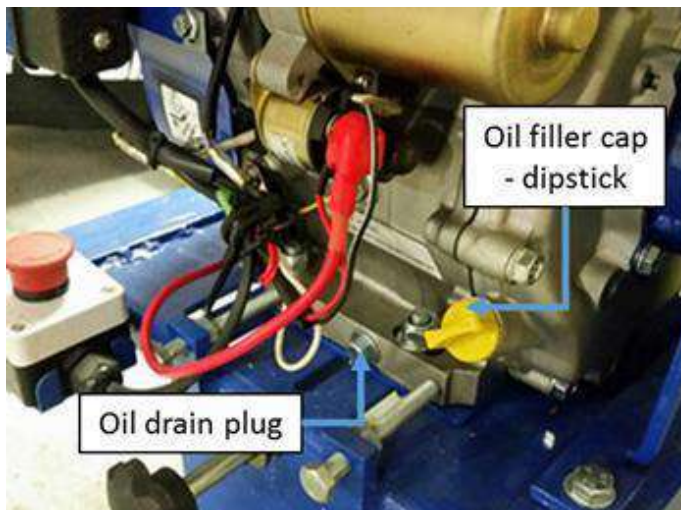

8. STORAGE & WINTERIZATION



NOTE

If the machine is to be stored for Winter or for periods of more than 30 days, then you **MUST** follow the correct storage procedure. Failure to do so may result in poor starting, performance issues and machine failure that will not be covered by the warranty.

- 7.0 Allow the engine to cool completely before storing the machine.
- 7.1 Drain the fuel from the fuel tank into a suitable container and then run the machine until it cuts out to drain the remaining fuel from the fuel lines and carburettor.
- 7.2 Drain and replace the engine oil as specified in the maintenance section.
- 7.3 Remove the spark plug and pour 1 teaspoon of fresh engine oil down the cylinder bore.
- 7.4 Place a clean lint free cloth over the spark plug hole and gently pull the recoil start handle 4 to 5 times to coat the cylinder wall with fresh oil, then refit the spark plug.
- 7.5 Clean the machine thoroughly with a damp cloth.
- 7.6 Use a silicone based grease and coat the cutting teeth to prevent rust.
- 7.7 Lubricate all cables and moving parts of the machine.
- 7.8 Top up the grease level at the grease point.
- 7.9 Check the tightness of all bolts.
- 7.10 Store in a cool, dry place away from sources of ignition.
- 7.11 DO NOT stack other items on top the machine.

9. TRANSPORTATION

- 8.0 The stump grinder has been designed to be transported by van or trailer.
- 8.1 With assistance, lift the machine in the van or trailer.
- 8.2 Ensure the machine is supported and strapped down securely to prevent it moving during transport.
- 8.3 DO NOT transport the machine while full of fuel and ensure the fuel tap is in the OFF position.

10. TROUBLESHOOTING

- 9.0 If troubleshooting does not resolve your issue, then contact the service dealer. Use only parts recommended or supplied by the manufacturer.

ENGINE WILL NOT START

Fuel System

9.1 **POSSIBLE CAUSES**

1. Fuel valve is in CLOSED position.
2. Choke OPEN.
3. Fuel tank empty.
4. Machine stored incorrectly.
5. Water in the fuel system.
6. Carburettor problem.

POSSIBLE CORRECTIVE ACTION

1. Move the fuel valve to OPEN.
2. Move the choke to the CLOSED position.
3. Check and fill with fuel.
- 4/5. Check and clean the fuel tank, fuel line & carburettor of sludge.
6. Contact your service dealer.

Spark Plug

POSSIBLE CAUSES

1. Incorrect spark plug.
2. Dirt or carbon build up on electrode.
3. Spark plug short circuit.
4. Incorrect plug gap.
5. Petrol/Oil on spark plug.
6. Faulty engine switch.

POSSIBLE CORRECTIVE ACTION

1. Replace with the correct spark plug.
2. Clean and check spark plug gap, replace if required.
3. Replace with correct plug.
4. Check and re-gap the plug to 0.6 – 0.7mm.
5. Clean the spark plug, allow excess fuel to evaporate. Start on full throttle.
6. Contact your service dealer.

Low Compression

POSSIBLE CAUSES

1. Serious internal engine damage.

POSSIBLE CORRECTIVE ACTION

1. Call your service dealer.

Fuel System

POSSIBLE CAUSE

1. Machine stored incorrectly with regards to emptying the fuel system.

POSSIBLE CORRECTIVE ACTION

1. Check and clean fuel tank, fuel lines and carburettor of sludge.

Belt Coming Off

POSSIBLE CAUSE

1. Pulleys not aligned.
2. Incorrect belt tension.

POSSIBLE CORRECTIVE ACTION

1. Align pulleys.
2. Re-tension the belt.

Engages Late

POSSIBLE CAUSE

1. Loose belt.
2. Incorrect cutting depth.

POSSIBLE CORRECTIVE ACTION

1. Tighten the belt.
2. Reduce cutting depth.

Cutting wheel does not rotate

POSSIBLE CAUSE

1. Insufficient speed.
2. Incorrect belt tension.
3. Faulty clutch shoes, springs and/or clutch bearings.

POSSIBLE CORRECTIVE ACTION

1. Speed up the engine.
2. Re-tension the belt.
3. Replace clutch shoes, springs and clutch bearings.

11. SPECIFICATION

HYSG150-2	
Engine type	4-stroke OHV
Maximum output – hp	14
Displacement - cc	420
Ignition system	CDI
Start method	Recoil
Fuel type/tank capacity - L	Unleaded Petrol / 6 Litres
Engine oil capacity - ml	1200
Engine oil	SAE30 or 15w40
Brake	Drum Brake
Drive	2PCS v Belt
Clutch	Centrifugal
Cutters	9 Blades with Tungsten Carbide tips (3x left, 3x right, 3x middle)
Cutting depth – inches	12
Net weight - kg	110

12. DECLARATION OF CONFORMITY

EC Declaration of Conformity

We hereby declare that the machine detailed in this declaration complies to all the relevant provisions of the following EC directives.

- 2006/42/EC The Machinery Directive
- 2014/30/EU Annex II Electromagnetic Compatibility Directive
- 2016/1628/EC The Emission of Gaseous and Particulate Pollutants from internal Combustion engines
- 2000/14/EC Noise Emissions in the Environment by Equipment for use Outdoors.

And is in conformity with the applicable requirements of the following documents:

- EN ISO 12100:2010, BS EN ISO 14120:2015
- EN13683:2003+A2:2011+AC:2015
- EN ISO 14982:2009

Declaration for 2000/14/EC Noise Emissions in the Environment by Equipment for use Outdoors.

Model	Type	Engine size	Measured Sound Power	Guaranteed Sound Power	Engine speed (rpm)
HYSG150-2	Petrol stump grinder	420cc	97.8dB(A)	116dB(A)	3400

Product Details

Brand: Hyundai

Model: HYSG150-2

Description: Petrol stump grinder

Name and address of technical documentation holder and EU distributor:

Genpower Ltd, Isaac Way, Pembroke Dock, Pembrokeshire, SA72 4RW, UK.



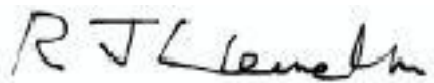

Signed by:



Roland Llewellyn, Managing Director

Date: 26/03/2020

13. RECYCLING & PRODUCT DISPOSAL

- 11.0 We do not offer a take back scheme for the recovery of Waste Electrical Electronic Equipment (WEEE) & Batteries instead the responsibility to dispose of WEEE and or Batteries passed onto you by us. So when it becomes necessary to dispose of your machine you must take it to your local Civic Amenity Site. For further information, please contact your Local Authority for disposal advice.
- 11.1 You MUST make sure that all unused oil and fuel is disposed of correctly either beforehand or at your local Civic Amenity Site. Under NO circumstances must any oil and fuel be put down the drains.
- 11.2 Waste Electrical Electronic Equipment (WEEE) recycling.
- 11.3  Certain products contain WEEE waste which should not be disposed of in your domestic waste.
- 11.4  You MUST recycle WEEE in accordance with your local authority or recycling center.
- 11.5  Battery recycling, certain products contain batteries which should not be disposed of in your domestic waste.
- 11.6  You MUST recycle batteries in accordance with your local authority or recycling center.
- 11.7 Unwanted packaging materials should be sorted and taken to a recycling center so it can be disposed of in a manner which is compatible with the environment.
- 11.8  This symbol means that you should 'Reduce – Reuse – Recycle'.
- 11.9 We are members of the VALPAK National Compliance scheme and our registration number is RM08660.
- 11.10 For further information about disposal please contact your Local Authority.
- 11.11 You can also get more advice and guidance about recycling at the following website <http://www.recycle-more.co.uk>
- 11.12 Should you pass this product on to another user either sold or loaned you MUST pass on this user manual. This will make sure that all other users can use and maintain the machine safely.

14. CONTACT DETAILS

Our friendly aftersales team will be more than happy to help you.

Phone

Call our team on 01646 687 880, open Monday-Friday 8.30am-5pm.

Email

aftersales@hyundaipowerproducts.co.uk

Online Live Chat

Go to www.hyundaipowerproducts.co.uk

Live chat is open Monday-Friday from 8.30am-5pm.

Post

Genpower Ltd, Isaac Way, Pembroke Dock, Pembrokeshire. SA72 4RW, UK.

15. WARRANTY

For warranty information, please visit www.hyundaipowerproducts.co.uk

Proof of purchase will be required before you make a warranty claim.

16. MANUAL UPDATES

Our manuals are constantly being reviewed and updated. Should you find an error, omission or something unclear, please contact us for assistance.

We reserve the right to make any modifications without prior notice whenever necessary.

Our latest manuals are also placed online. All manuals can be downloaded at www.hyundaipowerproducts.co.uk

HYUNDAI
POWER PRODUCTS

Importer:

GENPOWER LTD

Isaac Way, London Road

Pembroke Dock, UNITED KINGDOM, SA72 4RW

T: +44 (0) 1646 687 880 F: +44 (0) 1646 686 198

E: info@hyundaipowerproducts.co.uk

www.hyundaipowerproducts.co.uk

Imported/Distributed by GENPOWER LTD for The United Kingdom & Ireland

Licensed by Hyundai Corporation, Korea